

Military Intelligence

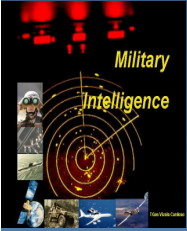

TGen Vizela Cardoso



Military Intelligence

SUMMARY

- 1. Intelligence and Strategy**
- 2. The National Intelligence System**
(Sistema de Informações da Republica Portuguesa – SIRP)
- 3. The Military Intelligence**
- 4. Conclusions**



Military Intelligence

EVOLUÇÃO HISTÓRICA DO SIRP

TIPO DE INFORMAÇÕES(1) \ CRONOLOGIA (2)	1974	1982	1984<->85	1987	1995	1997	1998	2004
INFO MIL			SIM					DIMIL
INFO EXT	PIDE		SIM		SIED		SIEDM	SIED
INFO INT	DGS		SIM				SIS	

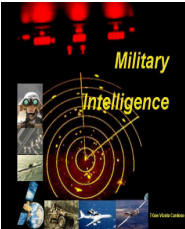

Military Intelligence

ORGANIZAÇÃO DO SIRP

Siglas:

- AR – Assembleia da República
- CCEM – Conselho de Chefes de EM
- CFD – Comissão de Fiscalização de Dados
- CFSI – Conselho de Fiscalização dos Serviços de Informações
- CSI – Conselho Superior de Informações
- DIMIL – Divisão de Informações Militares
- EMGFA – Estado Maior General das FA
- MDN - Ministério da Defesa Nacional
- PM – Primeiro Ministro
- PGR – Procuradoria Geral da República
- SIED – Serviço de Informações Estratégicas de Defesa
- SIRP – Sistema de Informações da República Portuguesa
- SIS – Serviço de Informações de Segurança

Legenda:

- Dependência Funcional
- - - - - Fiscalização
- Coordenação

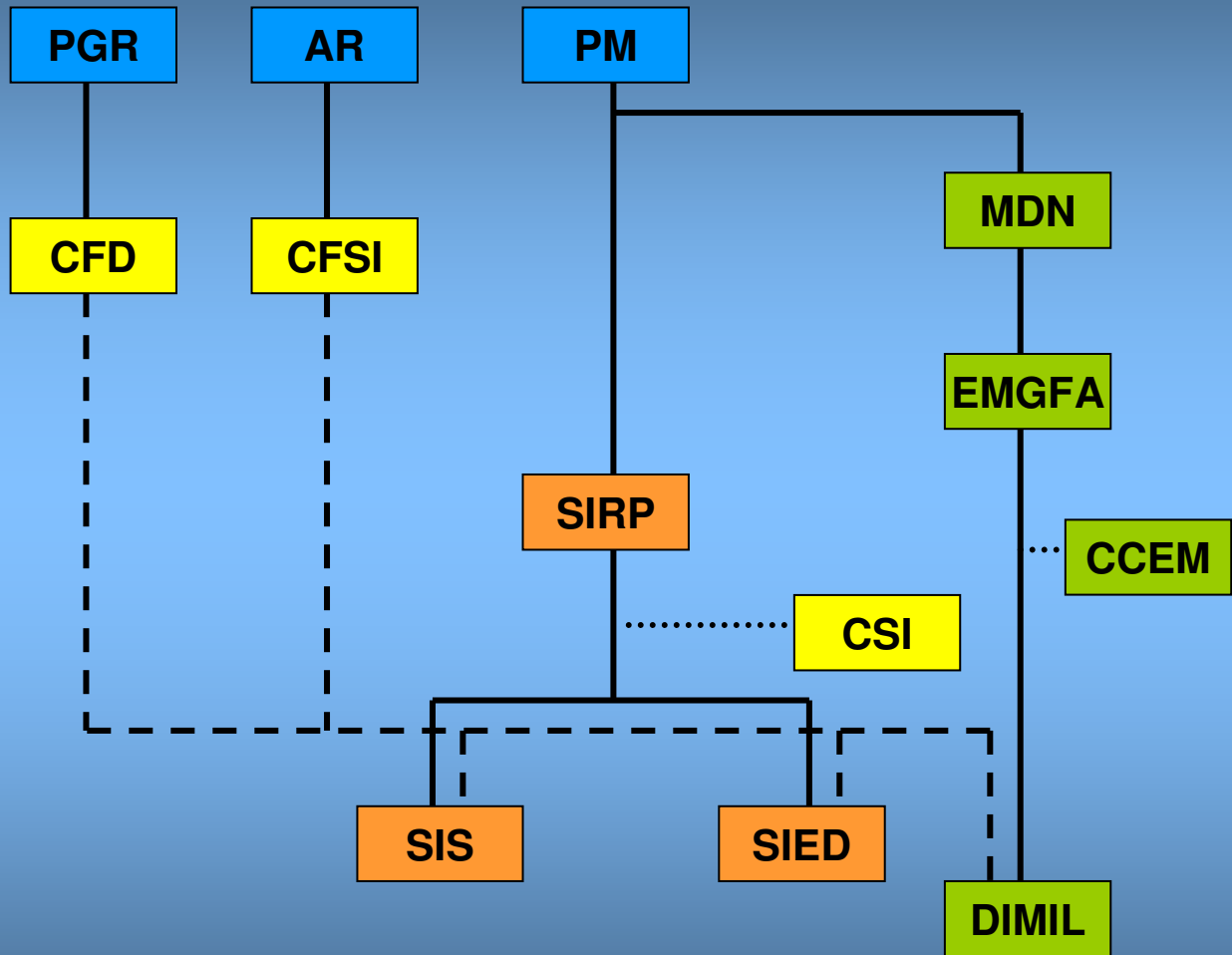

PRODUÇÃO DAS INFORMAÇÕES MILITARES

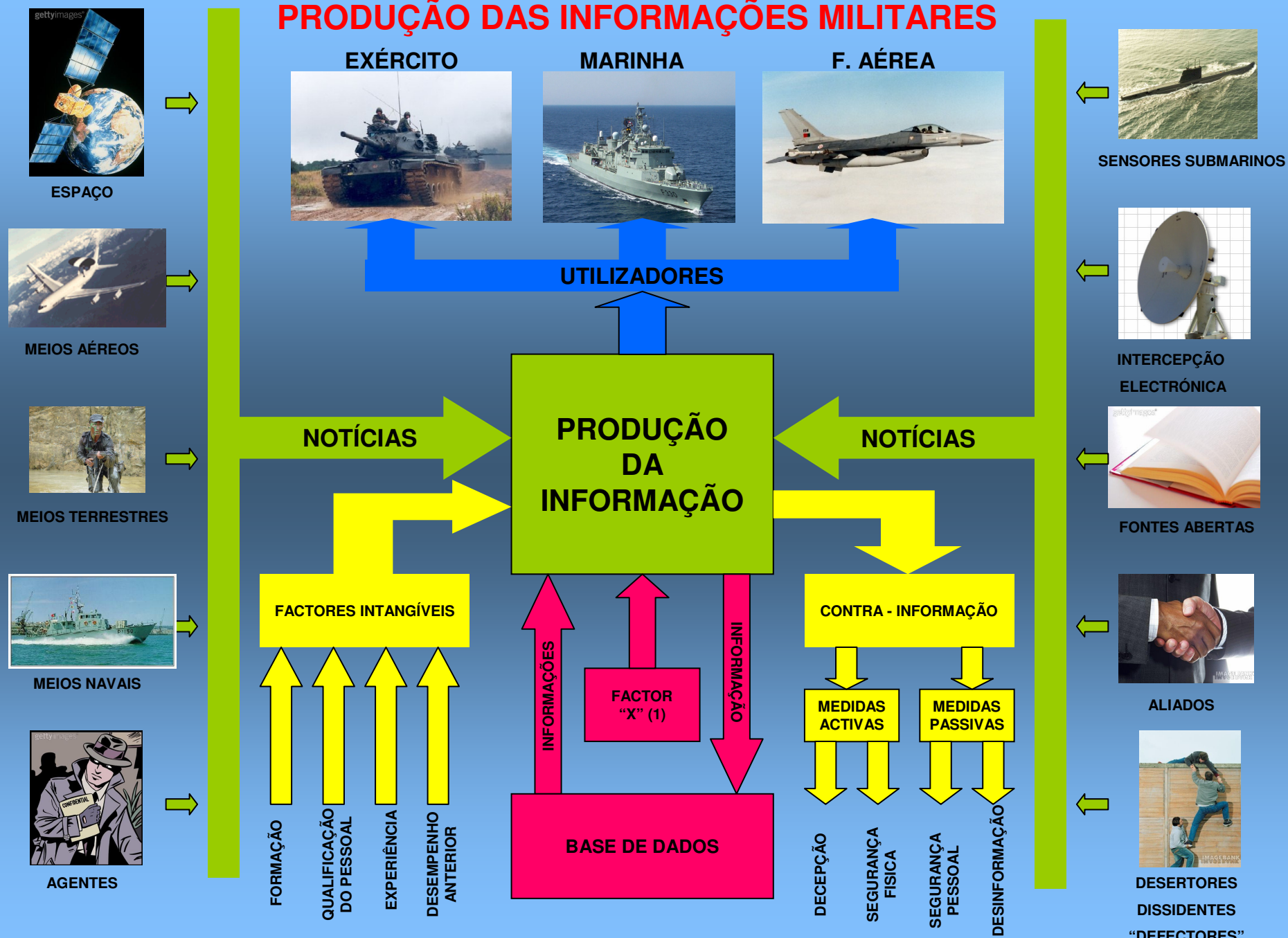

Obs: (1) Factor "X": Habilidade / capacidade para estar no local certo, no momento certo; saber quem é uma peça fundamental na informação; ter sorte.

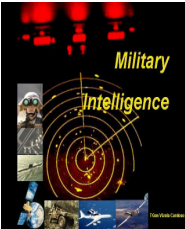

Military Intelligence

SERVIÇO DE INFORMAÇÕES MILITARES (Modelo)

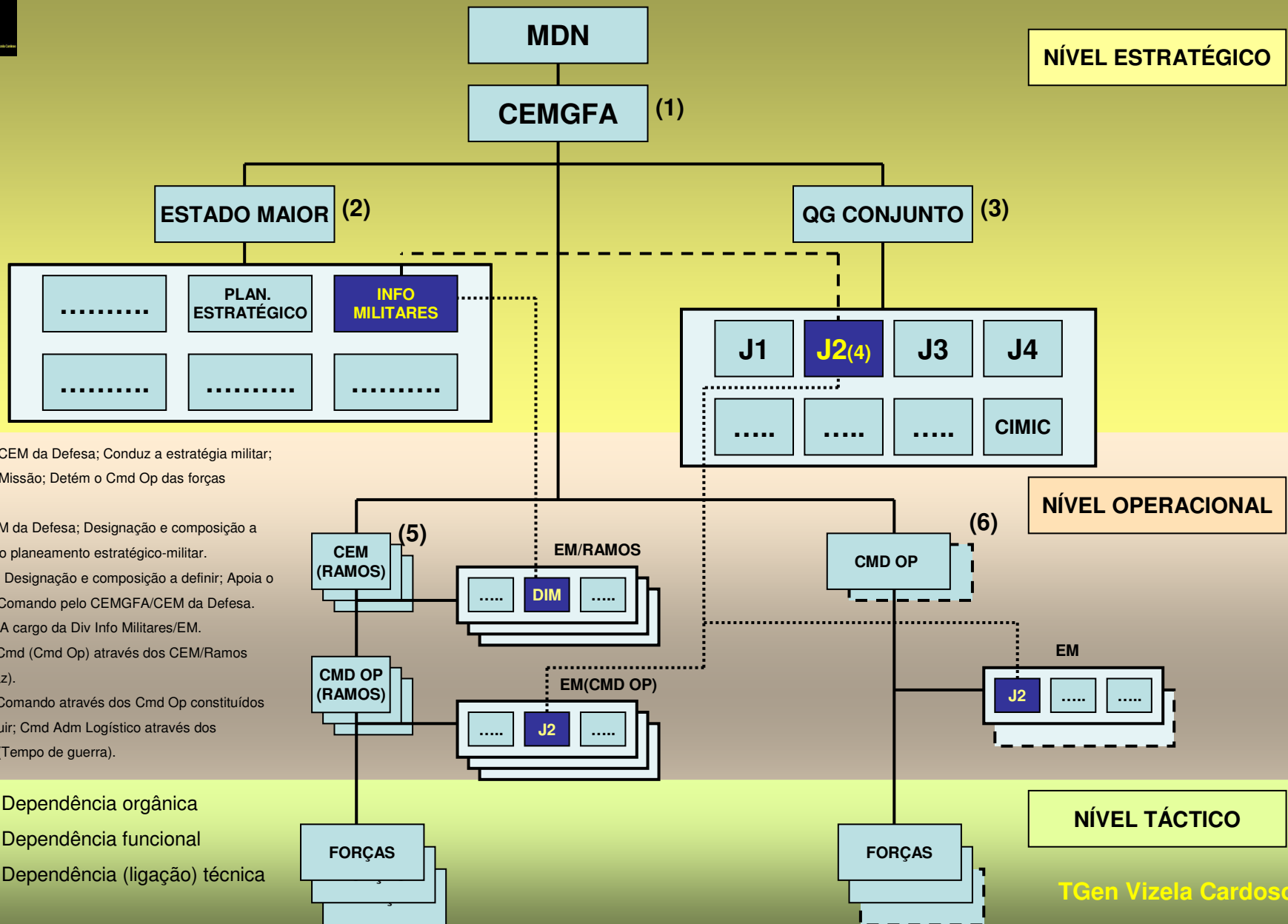

Obs.

(1) CEMGFA ou CEM da Defesa; Conduz a estratégia militar; Estabelece a Missão; Detém o Cmd Op das forças atribuídas.

(2) EMGFA ou EM da Defesa; Designação e composição a definir; Apóia o planeamento estratégico-militar.

(3) QG Conjunto; Designação e composição a definir; Apóia o exercício do Comando pelo CEMGFA/CEM da Defesa.

(4) ReplInfo (J2). A cargo da Div Info Militares/EM.

(5) Exercício do Cmd (Cmd Op) através dos CEM/Ramos (Tempo de paz).

(6) Exercício do Comando através dos Cmd Op constituídos e/ou a constituir; Cmd Adm Logístico através dos CEM/Ramos (Tempo de guerra).

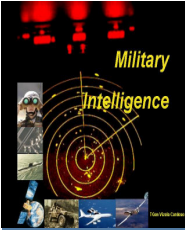

Military Intelligence

CONCLUSIONS

- Intelligence is an old, permanent and essential activity inside Armed Forces;
- The Armed Forces always have had organic structure appointed to the intelligence activity;
- The new threats have carried a great effort in the intelligence activity;
- The last organic law of the SIRP (Law 4/2004), brought important changes in the military intelligence organization;
- Reorganizations are taking place in the Defence Department and in the Armed Forces, in order to get:
 - More efficacy in the decision process;
 - Better efficiency in the resources management;
 - Real capacity of joint employment of military forces;

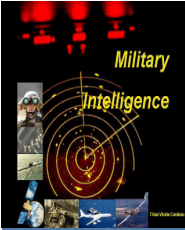

Military Intelligence

CONCLUSIONS (Cont.)

-The Chief of the General Staff, having the following competences:

- **Military adviser of the politic power;**
- **Responsible for the military strategic planning and its conducting;**
- **Commander (operational) of the Armed Forces;**

Needs to have:

- **A general staff (joint) for planning;**
- **A HeadQuarter (joint) to command the forces;**

- The model proposed may have some solutions for the questions we arose before.

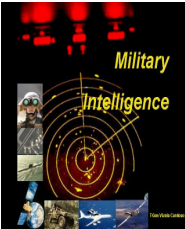

Military Intelligence

SERVIÇO DE INFORMAÇÕES MILITARES (Modelo)

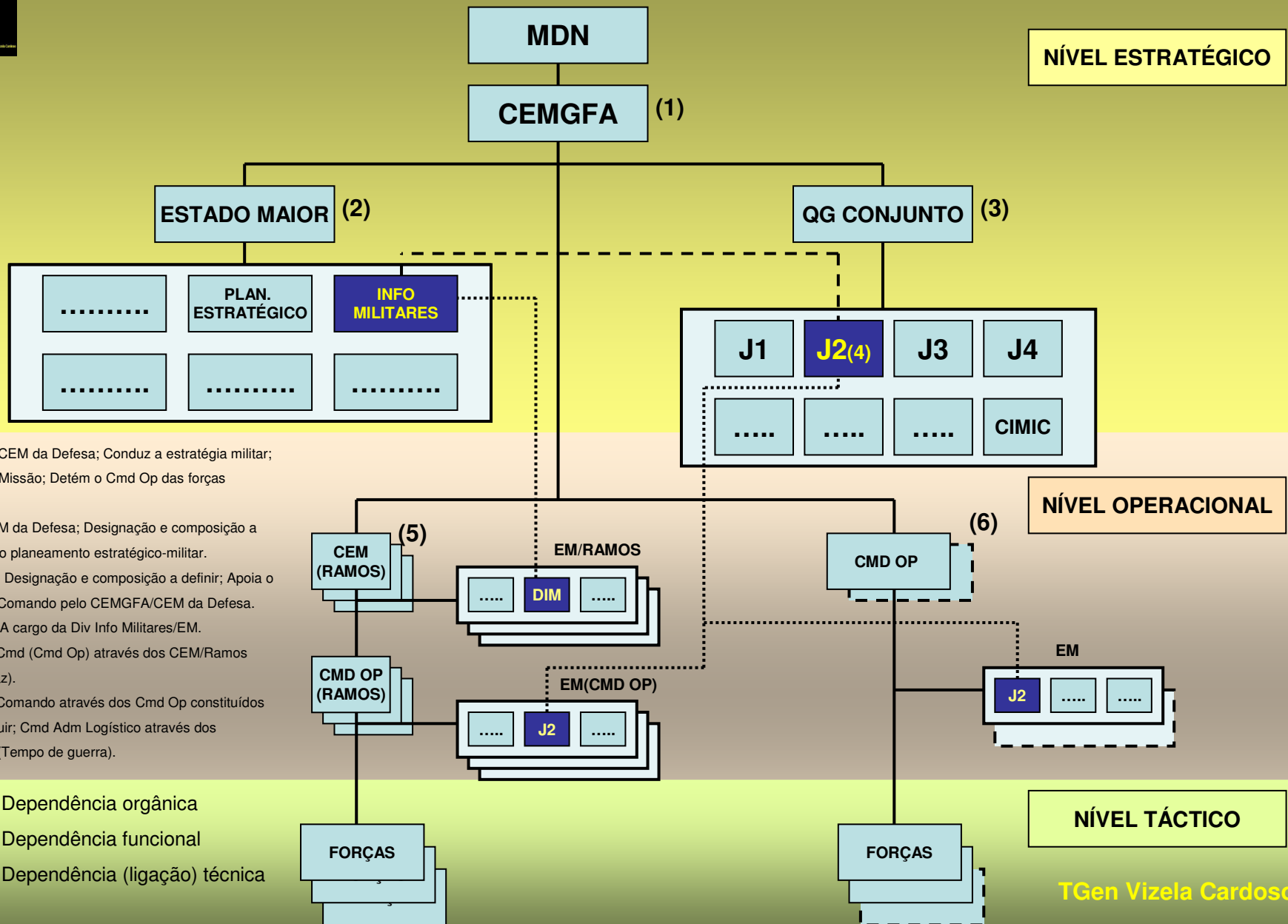

Obs.

- (1) CEMGFA ou CEM da Defesa; Conduz a estratégia militar; Estabelece a Missão; Detém o Cmd Op das forças atribuídas.
- (2) EMGFA ou EM da Defesa; Designação e composição a definir; Apoiar o planejamento estratégico-militar.
- (3) QG Conjunto; Designação e composição a definir; Apoiar o exercício do Comando pelo CEMGFA/CEM da Defesa.
- (4) ReplInfo (J2). A cargo da Div Info Militares/EM.
- (5) Exercício do Cmd (Cmd Op) através dos CEM/Ramos (Tempo de paz).
- (6) Exercício do Comando através dos Cmd Op constituídos e/ou a constituir; Cmd Adm Logístico através dos CEM/Ramos (Tempo de guerra).

Military Intelligence



TGen Vizela Cardoso